

Safety detection solutions

Emergency stop rope pull switches

XY2C range

Emergency stop rope pull switches

Emergency stop rope pull switches are designed to:

- avert hazards (dangerous phenomena) at the earliest possible moment, or to reduce risks which could cause injury to persons or damage either to machines or work in progress
- be tripped by a single human action when a normal emergency stop function is not available
- trip in the event of the rope pull breaking

Emergency stop rope pull switches are essential in premises and on machines that are potentially dangerous when operating. The operator must be able to trigger the stop instruction at any point within their working area.

Application examples: woodworking machines, shears, conveyor systems, printing machines, textile machines, rolling mills, test laboratories, paint shops, surface treatment works, etc.

XY2CJ, XY2CH and XY2CE emergency stop rope pull switches with single anchor point

- > 20 to 70 m cable
- > Rugged, compact offer, UL NiSD certified
- > Simple installation and maintenance using dedicated accessories (pilot light, quick tensioner, and cable tension indicator)

UL NiSD certified

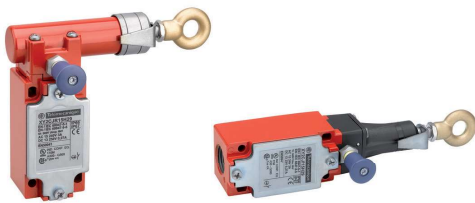

XY2CJ compact range



XY2CED emergency stop rope pull switches with double anchor points

- > Long cable (up to 2 x 100 m with supports and pulleys)
- > Rugged offer, UL NiSD certified
- > Easy mounting with aid of simple, dedicated accessories (removable shim for adjusting cable tension, quick tensioner, cable tension indicator, etc.)

2 x 100 m max. cable



XY2CED range with double anchor points



+ Certified, rugged safety devices that are easy to install

Safety detection solutions

Emergency stop rope pull switches

XY2C range

Installation

Description of a typical installation for XY2CJ, XY2CH and XY2CE (1)

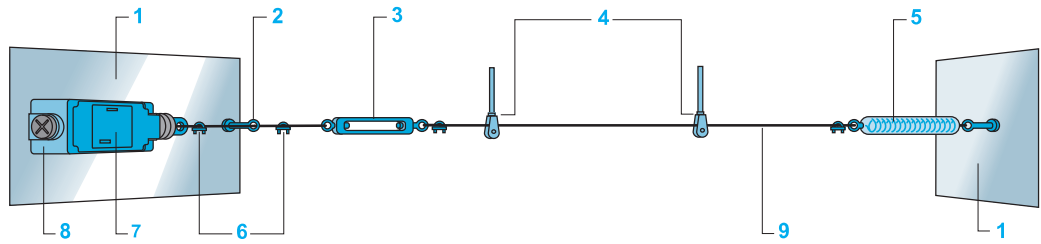

- | | | |
|-----------------------|-------------------------------|---------------------|
| 1 Mounting support | 4 Pulleys and pulley supports | 7 Switch adjustment |
| 2 First cable support | 5 End spring | 8 Emergency stop |
| 3 Turnbuckle | 6 Cable grips | 9 Cable |

Notes regarding installation

- XY2CJ, XY2CH, XY2CE and XY2CED emergency stop rope pull switches can be fitted with trip indicators (mechanical indicators for XY2CJ, pilot lights for XY2CH, XY2CE and XY2CED).
- The cable tension can be adjusted using:
 - a turnbuckle to be ordered separately (see [page 12](#))
 - a quick tensioner integrated in XY2CH emergency stop rope pull switches and optional for XY2CJ, XY2CE and XYCED emergency stop rope pull switches
- This adjustment is simplified by:
 - a cable tension indicator that is available on XY2CJ, XY2CH and XY2CE models. XY2CE emergency stop rope pull switches incorporate a cable tension indicator that is visible with the cover open. There is also an optional version with a window for viewing the cable tension, so that it can be adjusted when the cover is closed (excludes XY2CED models).
- For XY2CED emergency stop rope pull switches with double anchor points, the cable tension is visible on both end springs. A removable adjustment shim can be used to preset the balance between the left and right anchor points. The end springs and shim are supplied with the product.
- The use of an end spring is mandatory for conveyor system applications to allow operation of the emergency stop in the event of the cable being pulled towards the switch.
- For XY2CED switches, use of the model-specific end springs is mandatory, regardless of the application.
- It is essential that pulleys be used with cables that deviate from a straight run (within the permissible angles. Refer to the mounting instructions).

Basic principles

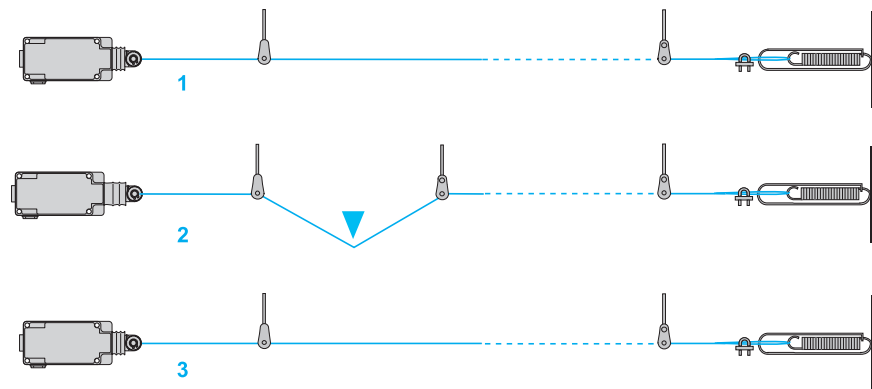

- | | | |
|---|---|---|
| Positive operation: running condition | 1 | The switches incorporate positive opening operation contacts, the tripping of the switch being made with positive action. |
| Latching: stop instruction given (tripped) | 2 | The switch latches in the tripped position (NC safety contact(s) open). The function of the NO contact is purely for signaling. |
| Resetting: stop condition (awaiting reset/restart) | 3 | The switches incorporate a reset button, which re-closes the safety contact. The machine must only be restarted by manual operation of a control device within the machine start circuit, remote to the emergency stop. |

(1) See the description of a typical XY2CED installation on our website www.tesensors.com

Safety detection solutions

Emergency stop rope pull switches

XY2C range

Rope pull expansion or contraction: d

This is the expansion or contraction of the rope pull cable. Temperature variations encountered on site are mainly responsible for these variations in length.

To enable instant verification that the rope pull is at its correct tension (and make any necessary adjustments), XY2CJ, XY2CH, and XY2CE emergency stop rope pull switches incorporate a cable tension indicator.

XY2CE emergency stop rope pull switches incorporate a cable tension indicator that is visible with the cover open. They are also available with a window for viewing the cable tension, enabling instant verification that the rope pull is at its correct tension (and to allow any necessary adjustments to be made) (excludes XY2CED models).

For XY2CED, the cable tension indicator is visible on the model-specific end springs supplied with the product.

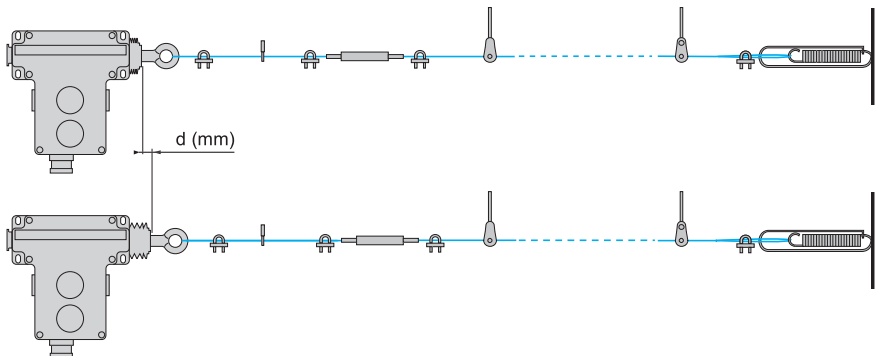

Standards

XY2CJ, XY2CH, XY2CE, and XY2CED switches meet the requirements of the harmonized European standard **EN/ISO 13850**, relating to "Emergency stop devices". The switches are **CE** marked and supplied with an EC declaration of conformity.

Cable diameter

In order to achieve the maximum cable length, according to ambient temperature variation, we recommend use of:

- galvanized cables with red sheath, diameter 3.2 mm for XY2CJ and XY2CH ranges
- galvanized cables with red sheath, diameter 5 mm for XY2CE and XY2CED ranges (see [page 12](#))

Adjustment values with end spring

For XY2CE emergency stop rope pull switches, the adjustment values depend on the positions of the cam located inside the switch. The adjustment is made by rotating the cam after the switch has been installed.

Each notched cam position is referenced by the letters A to F and the selected letter is visible through a viewing window.

The use of end springs is strongly advised (mandatory for XY2CED).

The references for each type are given in the table below:

Type	Cam position	Maximum cable length	End spring
XY2CJS	–	20 m	XY2CZ703
XY2CJR and XY2CJL	–	30 m	XY2CZ703
XY2CH	–	30 m	XY2CZ703
XY2CE	A, B, C, D, E, F	70 m	XY2CZ702
XY2CED	–	2 X 100 m (with pulleys) 2 x 70 m (with fixed cable supports)	XY2CZ712 (2 end springs supplied with the product)

XY2CJ

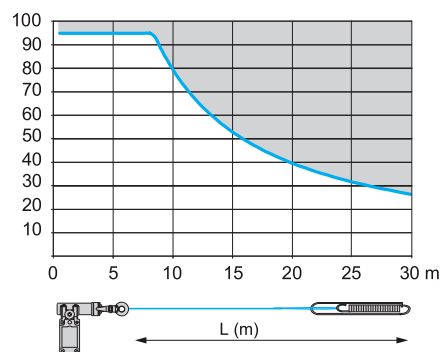
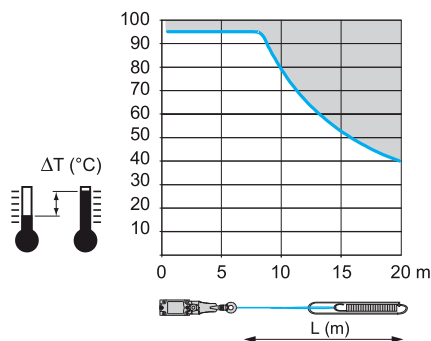

■ : Prohibited zone
With the graphs above, if we consider an ambient temperature variation of 25 °C, for example from 0 °C to + 25 °C, the table gives us a maximum cable length of 20 m for XY2CJS and 30 m for XY2CJR and XY2CJL.

Adjustment values with end spring
(continued)

XY2CH

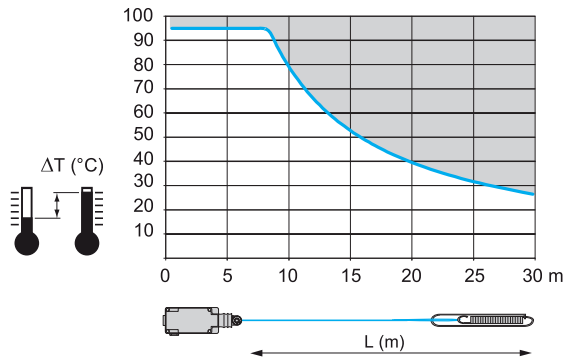

With the graph above, if we consider an ambient temperature variation of 25 °C, for example from 0 °C to +25 °C, the table gives us a maximum cable length of 30 m.

XY2CE

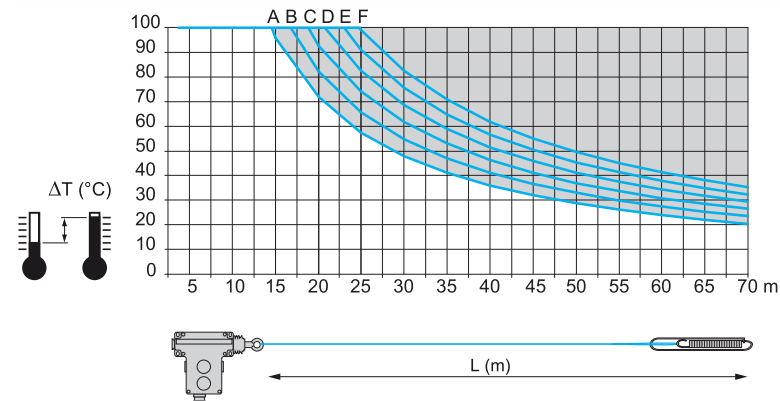

With the graph above, if we consider an ambient temperature variation of 35 °C, for example from -10 °C to +25 °C, the table gives us a maximum cable length of:

- 40 m, with cam A adjustments
- 70 m, with cam F adjustments

XY2CED

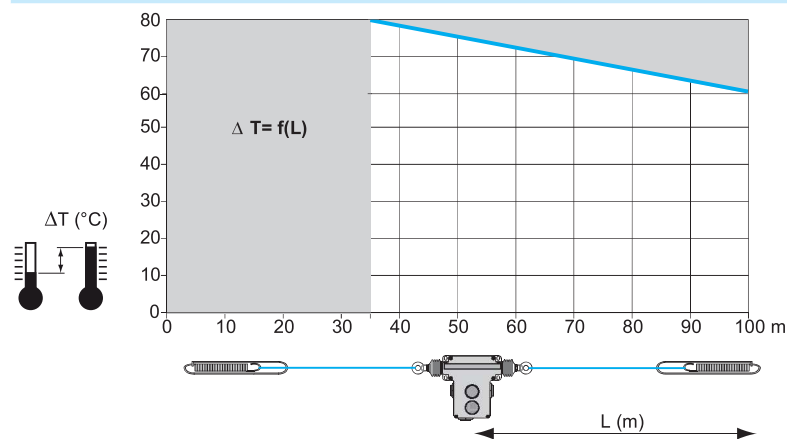

: Prohibited zone

With the graph above, if we consider an ambient temperature variation of 65 °C, the maximum cable length on each side will be 85 m (2 x 85 m).

Safety detection solutions

Emergency stop rope pull switches

XY2C range

Environment		
Conforming to standards	Products	EN/IEC 60947-5-5, EN/ISO 13850, UL 508 and CSAC 22-2 no. 14
	Machine assemblies	EN/IEC 60204-1, Machinery directive: 2006/42/EC Work equipment directive: 2009/104/EC
Product certifications		XY2CJ : UL (NISD) - CSA, CCC, EAC XY2CH : UL (NISD) (1) - CSA (with suffix H7) (1), EAC, CCC (1) XY2CE, XY2CED : UL (NISD) - CSA, EAC, CCC
Maximum safety level (2)		PL e, category 4 conforming to EN/ISO 13849-1 and SIL CL3 conforming to EN/IEC 62061
Reliability data B _{10d}		XY2CJ : 500,000 XY2CH : 4,000,000 XY2CE, XY2CED : 300,000 (Values given for a service life of 20 years but may be limited by contact and mechanical wear)
Ambient air temperature	For operation	- 25...+ 70 °C (- 40...+ 70 °C for XY2CH, XY2CE and XY2CED with booted reset pushbutton and silicone bellows) (3)
	For storage	- 40...+ 70 °C
Vibration resistance		XY2CJ, XY2CH : 10 gn (10... 150 Hz) XY2CE, XY2CED : 10 gn (10... 300 Hz) conforming to EN/IEC 60068-2-6
Shock resistance		XY2CJ, XY2CH, XY2CE : 50 gn (duration 11 ms) conforming to EN/IEC 60068-2-27 XY2CED : 35 gn (duration 11 ms) conforming to EN/IEC 60068-2-27
Electric shock protection		Class I conforming to IEC 61140
Degree of protection		XY2CJ : IP 66 and IP 67 conforming to IEC 60529 XY2CH, XY2CE : IP 65 conforming to IEC 60529 (IP 66 for XY2CE●A●●●, Y2CE●C●●●) XY2CED : IP 66 conforming to IEC 60529
Materials		XY2CJS : Zamak body, polyamide head, zinc-plated steel cover XY2CJL, XY2CJR : Zamak body and head, zinc-plated steel cover XY2CH, XY2CE, XY2CED : Zamak body, stainless steel cover
Mechanical life (no. of operating cycles)		XY2CJ : 100,000 XY2CH : 800,000 XY2CE, XY2CED : 60,000
Length of protected zone		XY2CJS : ≤ 20 m XY2CJR and XY2CJL : ≤ 30 m XY2CH : ≤ 30 m XY2CE : ≤ 70 m XY2CED : ≥ 2 x 35 m to 2 x 100 m
Distance between cable supports		XY2CJ, XY2CH, XY2CE : 5 m XY2CED : 3 to 5 m
Cable entries		XY2CJ, XY2CH : Tapped entries for ISO M20, Pg 13.5 or 1/2" NPT cable gland XY2CE, XY2CED : Untapped entries for ISO M20 or Pg 13.5 cable gland, tapped entries for 1/2" NPT cable gland See dimensions on page 16 .

(1) Only **XY2CH** products without pilot light are approved.

(2) When the emergency stop rope pull switch is used with an appropriate and correctly connected control system. Only models with 2 NC contacts can be used with an emergency stop monitoring safety relay.

(3) **XY2CH, XY2CE** and **XY2CED** with booted reset pushbutton and silicone bellows are designed for switching in a maximum operating temperature range of -40°C to 70°C / -40°F to 158°F. The emergency stop rope pull switch is only one component of the entire installation, the proper operation of the overall equipment must be checked regularly.
In case of particularly harsh environmental conditions, additional protection devices shall be implemented.

Safety detection solutions

Emergency stop rope pull switches

XY2C range

Contact block characteristics		
Rated operational characteristics	2-pole contact block	XY2CJ, XY2CH, XY2CE, XY2CED: AC-15: A300 or Ue = 240 V, Ie = 3 A DC-13: Q300 or Ue = 250 V, Ie = 0.27 A, conforming to EN/IEC 60947-5-1 Appendix A
	3-pole contact block	XY2CJ, XY2CH: AC-15: B300 or Ue = 240 V, Ie = 1.5 A DC-13: R300 or Ue = 250 V, Ie = 0.1 A, conforming to EN/IEC 60947-5-1 Appendix A
Nominal thermal current	2-pole contact block	10 A
	3-pole contact block	6 A
Rated insulation voltage	2-pole contact block	XY2CJ, XY2CH, XY2CE, XY2CED: Ui = 500 V degree of pollution 3 conforming to EN/IEC 60947-1, Ui = 300 V conforming to UL 508, CSA C22-2 no. 14
	3-pole contact block	XY2CJ, XY2CH: Ui = 400 V degree of pollution 3 conforming to EN/IEC 60947-1, Ui = 300 V conforming to UL 508, CSA C22-2 no. 14
Rated impulse withstand voltage	2-pole contact block	XY2CJ, XY2CH, XY2CE, XY2CED: Uimp = 6 kV conforming to EN/IEC 60947-1
	3-pole contact block	XY2CJ, XY2CH: Uimp = 4 kV conforming to EN/IEC 60947-1
Positive operation		NC contact with positive opening operation conforming to EN/IEC 60947-5-1 Section 3
Resistance across terminals		≤ 25 mΩ conforming to NF C 93-050 method A or EN/IEC 60255-7 category 3
Terminal referencing		Conforming to GENELEC EN 50013
Short-circuit protection	2-pole contact block	XY2CJ, XY2CH, XY2CE, XY2CED: 10 A cartridge fuse type gG (gl) conforming to EN/IEC 60269
	3-pole contact block	XY2CJ, XY2CH: 6 A cartridge fuse type gG (gl) conforming to EN/IEC 60269

Rated operational power (Electrical durability)
XY2CJ, XY2CH, XY2CE, XY2CED
 Conforming to EN/IEC 60947-5-1 Appendix C. Utilization categories AC-15 and DC-13
 Frequency: 3,600 operating cycles/hour. Load factor: 0.5

AC supply ~ 50/60 Hz
 ~ Inductive circuit

2-pole contact block

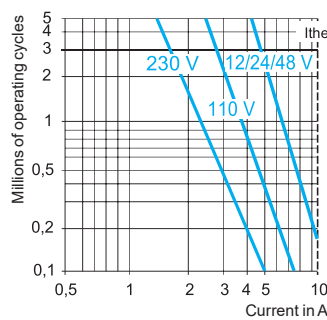

3-pole contact block

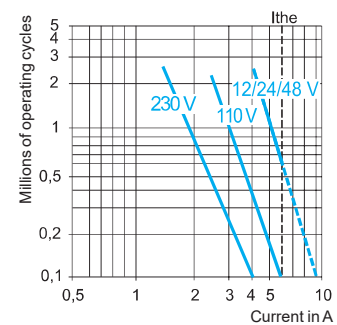

DC supply ---
 Breaking current
 for 1 million operating cycles.
 ~ Inductive circuit

Voltage V	24	48	120
~ Inductive circuit	13	9	7

Voltage V	24	48	120
~ Inductive circuit	4	3	2

Contact connection	Screw clamp terminals 2 contacts: clamping capacity, min. 1 x 0.5 mm ² /AWG 20, max. 2 x 1.5 mm ² /AWG 16 3 contacts: clamping capacity, min. 1 x 0.34 mm ² /AWG 22, max. 1 x 1 mm ² /AWG 18 or 2 x 0.75 mm ² /AWG 20 Minimum tightening torque: 0.8 N.m/7.1 lb-in. Maximum tightening torque: 1.2 N.m/10.6 lb-in.
---------------------------	--

Safety detection solutions

Emergency stop rope pull switches

XY2CJ range

Emergency stop rope pull switches with single anchor point ISO M20, Pg 13.5 and 1/2" NPT

Turnbuckle or quick tensioner, cable and end spring to be ordered separately (1)

Without pilot light

Cable length	Colors and materials	Reset	Supply voltage	Contact type	Cable anchor point	Reference	Weight kg	
≤ 20 m	Polyamide head Zamak red RAL 3000 body Treated steel cover	By pull button	–	1 1	RH side or LH side	XY2CJS15 (2)	0.455	
				2 –	RH side or LH side			XY2CJS17 (2)
				2 1	RH side or LH side			XY2CJS19 (2) (3)
≤ 30 m	Zamak red RAL 3000 head and body Treated steel cover	By pull button	–	1 1	RH side	XY2CJR15 (2)	0.669	
				2 –	RH side			XY2CJR17 (2)
				2 1	RH side	XY2CJR19 (2) (3)	0.669	
				1 1	LH side			XY2CJL15 (2)
				2 –	LH side	XY2CJL17 (2)	0.669	
				2 1	LH side	XY2CJL19 (2) (3)	0.669	



(1) See separate parts on [page 12](#).

(2) For ISO M20 tapped cable entry version, add H29 to the end of the selected reference.
For example: **XY2CJS15** becomes **XY2CJS15H29**.

(3) For 1/2" NPT tapped cable entry version, add H7 to the end of the selected reference.
For example: **XY2CJS19** becomes **XY2CJS19H7**.

Emergency stop rope pull switches with single anchor point ISO M20, Pg 13.5 and 1/2" NPT with integrated quick tensioner

Cable and end spring to be ordered separately (1)

Without pilot light

Cable length	Colors and materials	Reset	Supply voltage	Contact type	Cable anchor point	Reference	Weight kg	
≤ 30 m	Zamak red RAL 3000 body Stainless steel cover Chloroprene bellows	By flush pushbutton	–	1 1	NC + NO slow break	RH side or LH side	XY2CH13150 (4)	0.865
		By booted pushbutton	–	1 1			XY2CH13250 (3) (4)	0.865
		By mushroom head pushbutton	–	1 1			XY2CH13350 (4)	0.900
		By key-operated pushbutton (key no. 421) (2)	–	1 1			XY2CH13450 (3) (4)	0.910
≤ 30 m	Zamak red RAL 3000 body Stainless steel cover Chloroprene bellows	By flush pushbutton	–	2 –	NC + NC slow break	RH side or LH side	XY2CH13170 (3) (4)	0.865
		By booted pushbutton	–	2 –			XY2CH13270 (3) (4)	0.865
		By mushroom head pushbutton	–	2 –			XY2CH13370 (3)	0.865
		By key-operated pushbutton (key no. 421) (2)	–	2 –			XY2CH13470 (3) (4)	0.910
≤ 30 m	Zamak red RAL 3000 body Stainless steel cover Chloroprene bellows	By flush pushbutton	–	2 1	2 NC + 1 NO slow break	RH side or LH side	XY2CH13190 (3) (4)	0.865
		By booted pushbutton	–	2 1			XY2CH13290 (3) (4)	0.865
		By mushroom head pushbutton	–	2 1			XY2CH13390 (3) (4)	0.865

With orange pilot light (direct supply)

≤ 30 m	Red RAL 3000 body Stainless steel cover Chloroprene bellows	By booted pushbutton	24 V ~/–	1 1	NC + NO slow break	RH side or LH side	XY2CH13253 (3)	0.900
				2 –	NC + NC slow break		XY2CH13273	0.900
				2 1	2 NC + 1 NO slow break		XY2CH13293 (3)	0.950

Other versions

Versions with silicon bellows
Please contact our Customer Care Center.

(1) See separate parts on page 12.

(2) Ø 30 spring return key-operated mushroom head pushbutton.

(3) For ISO M20 tapped cable entry version, add H29 to the end of the selected reference.

For example: XY2CH13250 becomes XY2CH13250H29.

(4) For 1/2" NPT tapped cable entry version, add H7 to the end of the selected reference.

For example: XY2CH13190 becomes XY2CH13190H7.



XY2CH13250



XY2CH13450



XY2CH13170



XY2CH13253